

The diagram below shows four points motors and their switches. These have been wired to input terminals 1/2 5/6 11/12 & 15/16 Please note that we have only used those terminals so as to make the diagram clearer, also the diagram only shows four sets of switches and motors where there could be up to eight, again this is to keep it clear.

The red wires are the extra wires that are needed for the points status indicator, these best connected to the switches as the motors themselves would be dotted around the layout, the switches would all be in the same place. The LED indicators showing the points status would also be in the general area of the switches.
(layout/mimic panel etc)

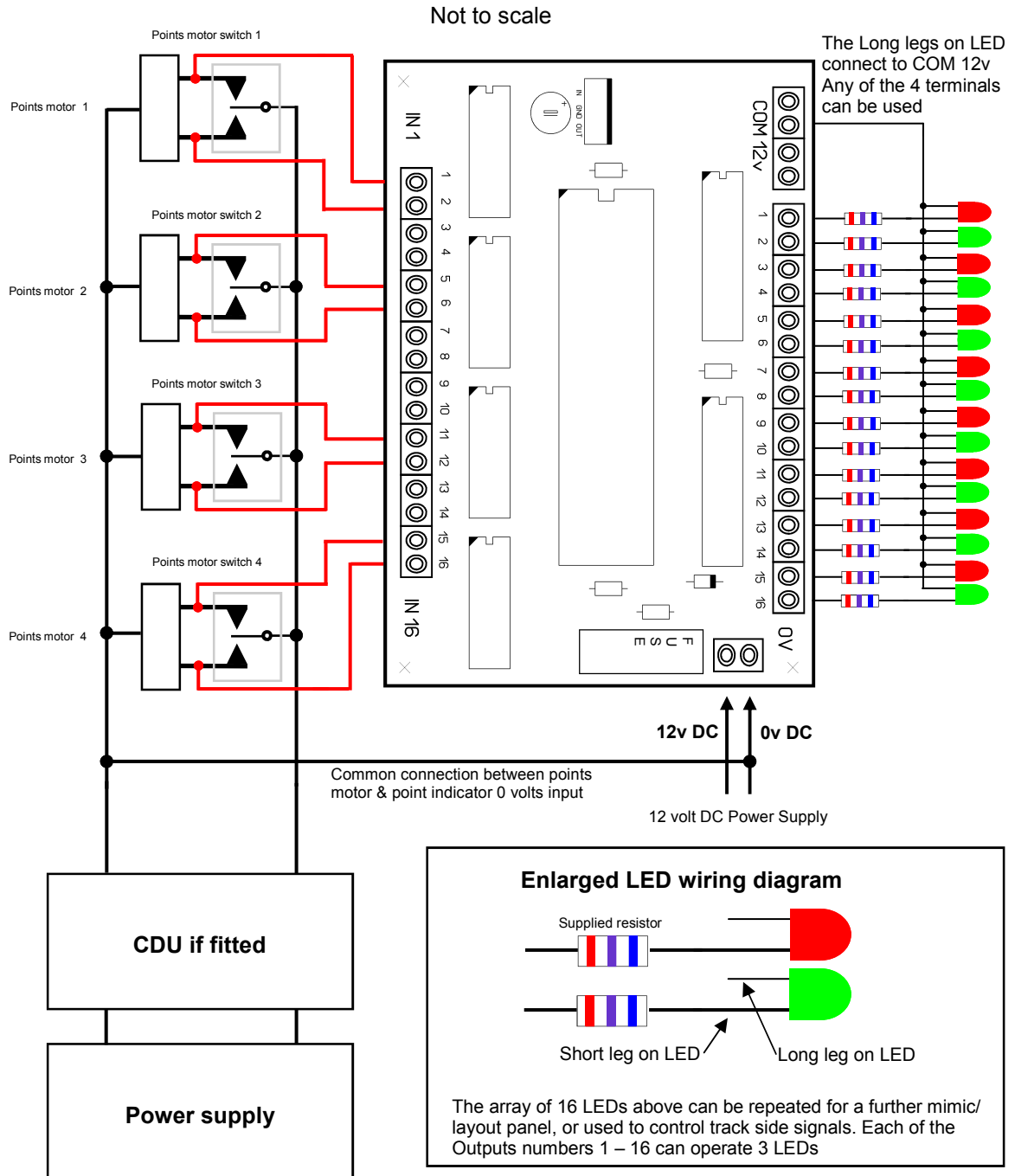

Please note:
CDU and its power supply are to be wired up in accordance with manufactures instructions